

F105 / PS50-TB

Semi-Automatic Case Erectors

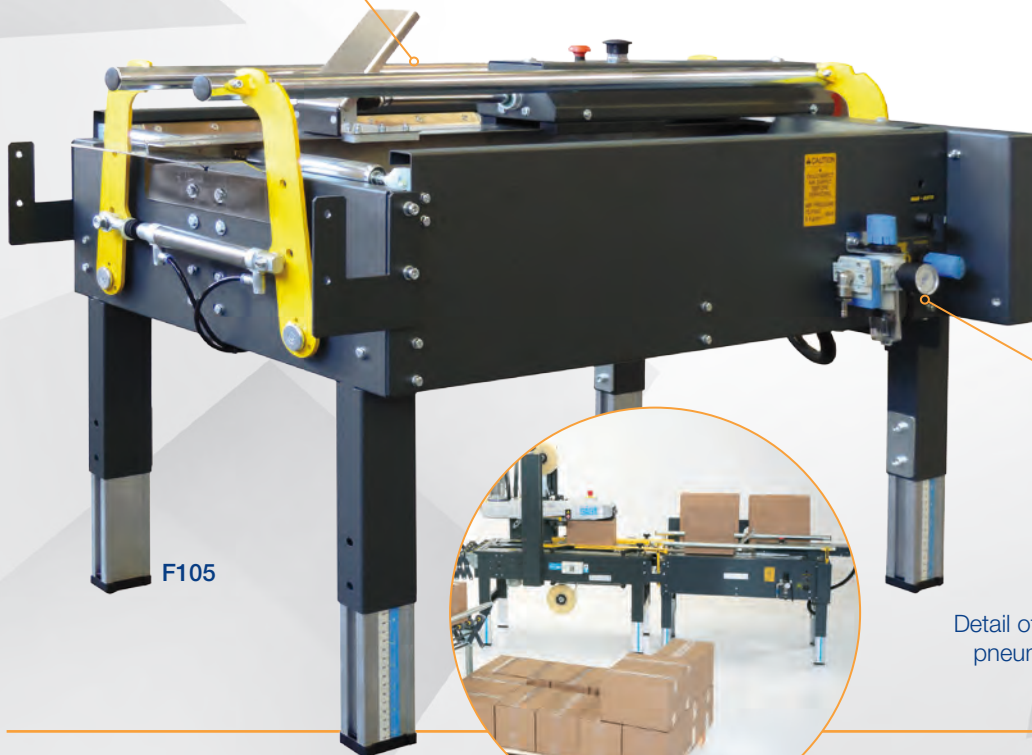
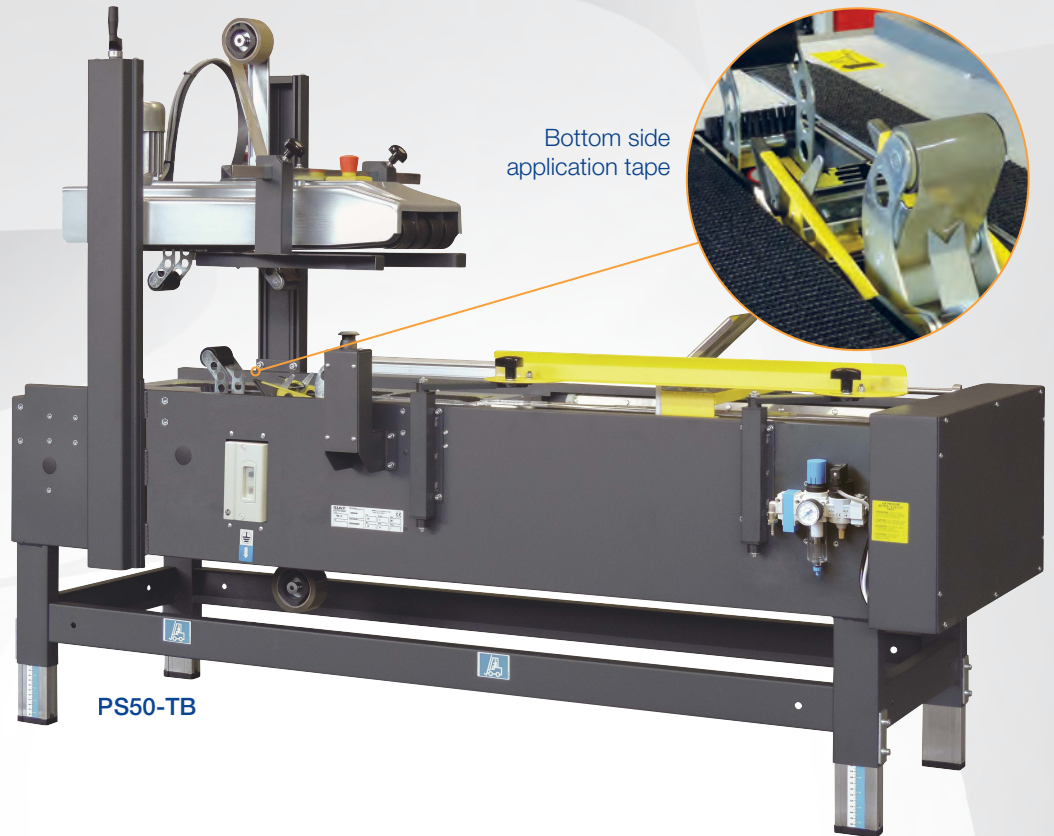

> **F105**
 La nastratrice F105 piega automaticamente i lembi delle scatole messi nella macchina da un operatore, permettendo un risparmio di tempo del 50%.

La scatola con i lembi inferiori piegati resta in posizione verticale per l'operazione di riempimento. Successivamente può essere spinta attraverso un cilindro pneumatico per sigillarla con nastro adesivo.

> **F105**

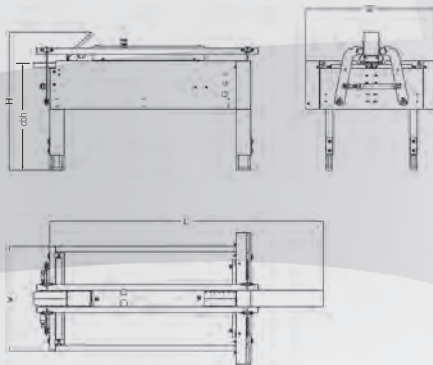

> **PS50-TB**

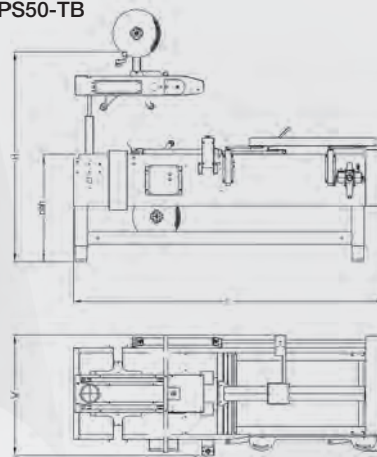

other languages: www.siat.com



> **Machine dimensions**
 Dimensioni macchina
 Machinemessungen
 Dimensions machine
 Dimensiones de la máquina

Size / Weigth packaging			LxWxH
> F105	110	125	148x88x95
> PS50	225	250	202x83x126

> **F105**

	Min.	Max
L	1260	1660
W	570	933
H	695	855
cbh	525	675
AS 77	775	935
AS 80	895	1055

> **PS50-TB**

	Min.	Max
L	1952	-
W	753	-
H	1305	1505
cbh	585	735
AS 77	685	885
AS 80	785	985

> **Taping units**
 Unità nastranti
 Verschliesseinheiten
 Unité enrubanneuse
 Unidades de precinto

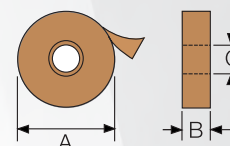

> **Box dimensions**
 Dimensioni delle scatole
 Kartonabmessungen
 Dimensions des boîtes
 Dimensiones de las cajas

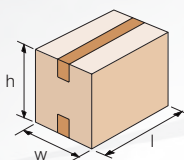

> **F105**

	Min.	Max
l	200	600
w	90	500
h	90	500

> **PS50-TB**

	K11R	
	Min.	Max
l	150	600
w	150	500
h	100	500

	K11R
	mm
A	410 Max
B	50
C	76

> **Production capacity**
 Capacità di produzione
 Produktionskapazität
 Capacité de production
 Capacidad de producción

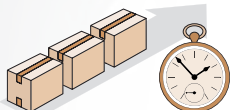

> **F105**

	Bph
Max pcs.*	600

> **PS50-TB**

	Bph
Max pcs.*	600

* Always based on shorter manageable box

> **Air consumption**
 Consumo aria
 Druckluftverbrauch
 Consommation air comprimé
 Consumo de arie

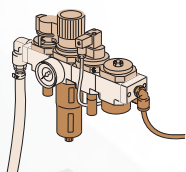

> **F105 / PS50-TB**

	NL.
Cycle	14,2

from 5,5 bar to 7 bar

> **PS50-TB**

380/400V - 50Hz - 3F	
440V - 60Hz - 3F	
Amps	1,08
Power kW	0,26
Phase	3Ph + N + PE

> **Standard voltage**
 Voltaggio standard
 Standardspannung
 Tension standard
 Voltaje estándar

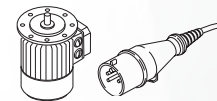

> **Optionals**
 Accessori
 Zubehör
 Accessories
 Accesorios

> **AS80**
 Higher legs
 Set gambe più alte
 Höhere Stützen
 Pieds plus hauts
 Patas más altas



> **AS77**
 Casters
 Set ruote
 Rädchen
 Roulettes
 Ruedas

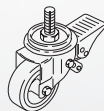

> **RG**
 Roller conveyor
 Piani a rulli
 Rollenbahnen
 Plans à rouleaux
 Rodillos libres



> **GTL - GTR**
 Extendable conveyor
 Rulliera estensibile
 Ausziehbare rollenbahnen
 Convoyeur extensible
 Rodillos extensibles

