

■ La nastratrice **SM1-P**, costruita secondo le norme CEE, sigilla scatole dello stesso formato applicando una striscia ad U di nastro adesivo sulla

parte superiore ed inferiore della scatola. Il dimensionamento della macchina al formato da nastrare è facile e veloce.

■ The carton sealing machine **SM1-P** has been designed according to the EEC regulations and it is able to seal uniform size cartons applying a U seal of pressure sensitive tape to the top and bottom seams. The adjustments to the carton sizes are fast and easy.

■ La machine d'emballage **SM1-P**, réalisée selon les normes CEE, ferme cartons du même format par la pose simultanée de 2 bandes de ruban adhésif sur les rabats supérieurs et inférieurs. Les réglages pour le changement de format sont simples et rapides.

■ Der gemäß den EG Normen geplante Boxenschließautomaten **SM1-P** eignet sich zum Verchluß von Kartonen gleicher Formaten mit Selbstklebeband U Verschluß auf der oberen und unteren Klappen. Die Umstellung auf andere Schachtelformate ist schnell und einfach.



SINTEESI
Soluzioni per l'industria

SM1-P

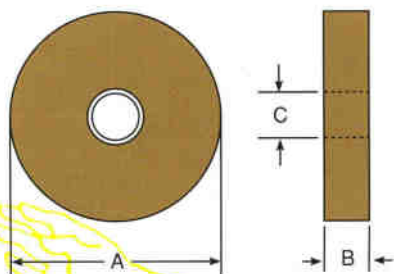

A = 410 mm
B = 50 mm (K11)
C = 76 mm

- Pulsante di emergenza
- Emergency stop button
- Bouton arrêt d'urgence
- Not-Ausschalter

- Pressatori laterali
- Side compression rollers
- Rouleaux de compression
- Seitliche Andrückrollen

- Unità nastranti
- Taping heads
- Unités d'enrubannage
- Verschliesseinheiten

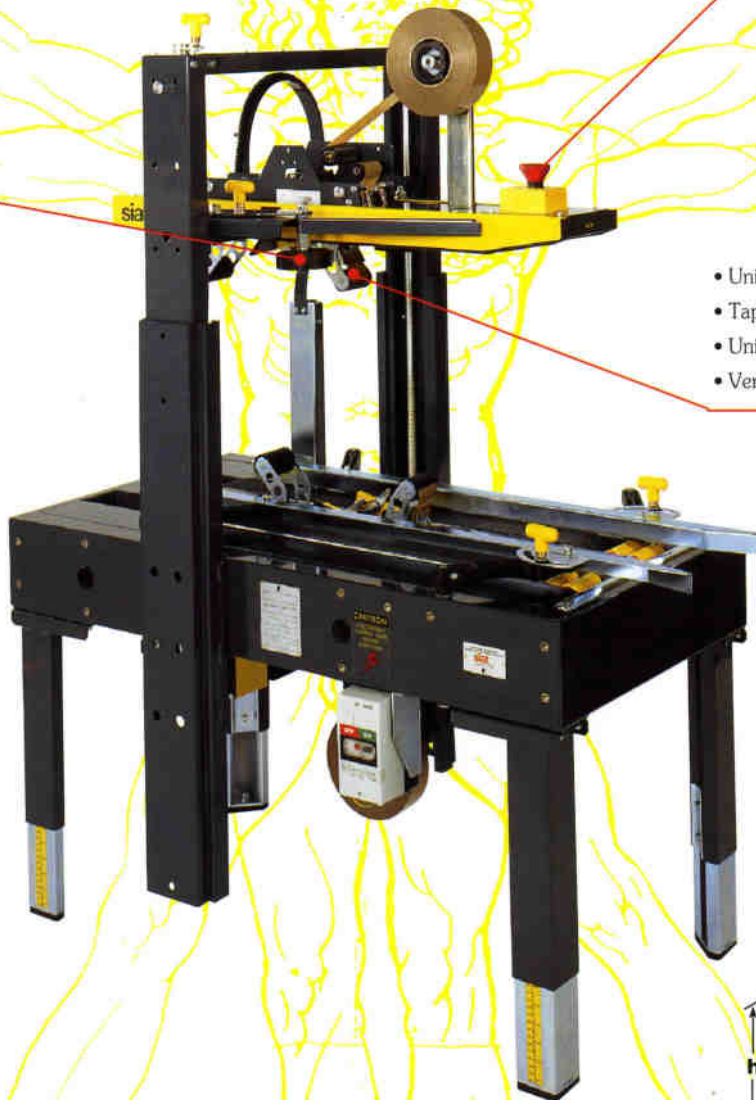

SM1-P	w	h	l
min.	130	120	150
max.	500	500	∞

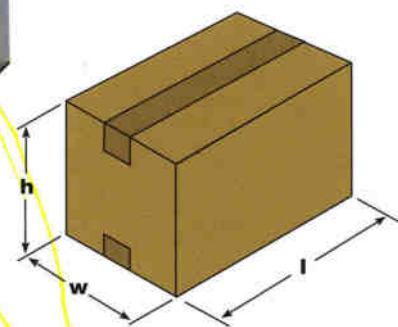

**OPTIONAL
AS 7**

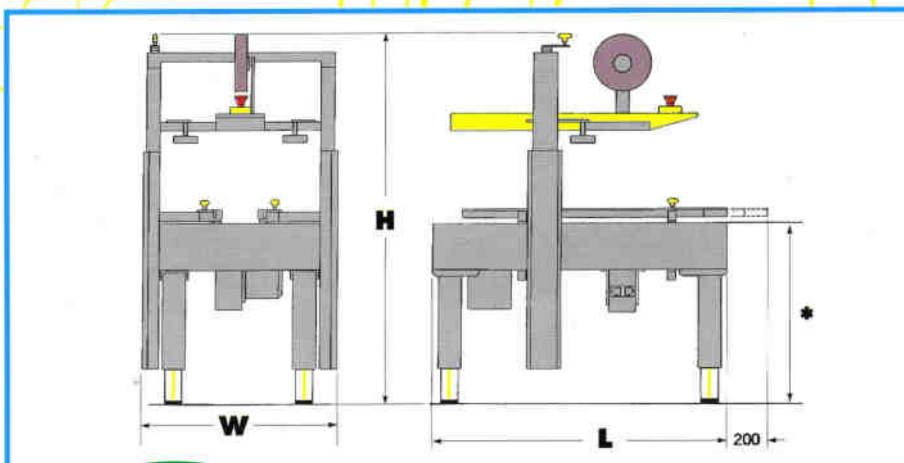

SM1-P	MIN.	MAX.
W	700	
L	1080	
H	1040	1440
* Stand.	530	780
* AS 8	700	1120

Sintesi

Soluzioni per l'industria
 Via F. Lippi 22/E - 50038 Scarperia (FI)
 Tel. 055 8430571 - Fax 055 846646
 www.sintesicom.it - sintesi@sintesicom.it