

XL35

Heavy Duty Carton Sealing Machines

Reliable sealing process thanks to our taping heads

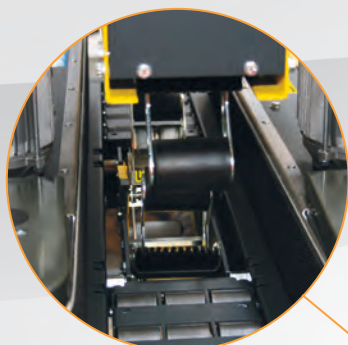

Sturdy "A frame" structure for heavy duty applications



Perfect box control with 75mm height side belts

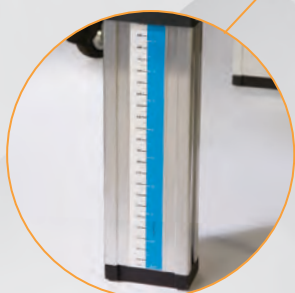

Easy infeed thanks to benchwork rollers

Reinforced welded steel frame 2mm thickness

Aluminium telescopic legs



The semi-automatic case sealing **XL35** represents the heavy duty solution in case of uniform size sealing needs. Easy to use and to adjust, it allows the perfect sealing of top and bottom boxes with pressure sensitive tape. Thanks to the self-centering screw adjustment device and the 75mm height belts, the perfect box management is always guaranteed.

XL35 model has been designed in compliance with CE regulations.

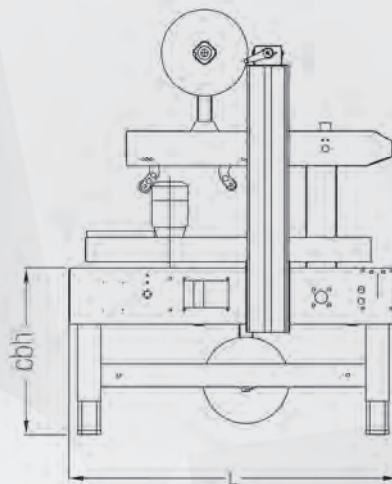
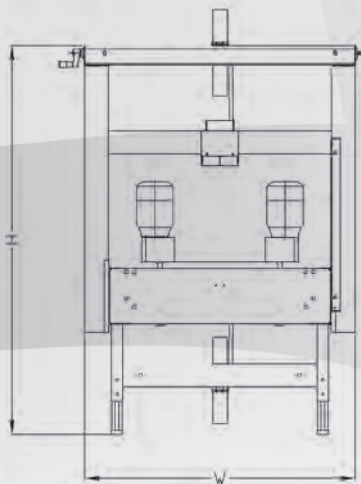

> **Machine dimensions**
Dimensioni macchina
Machinemessungen
Dimensions machine
Dimensiones de máquina

Size / Weight packaging			LxWxH
> XL35	185	220	120x106x116

> **XL35**

	Min.	Max
L	938	-
W	1140	-
H	1250	1590
cbh	480	820
AS 77	580	920
AS 80	680	1020

> **Taping units**
Unità nastranti
Verschliesseinheiten
Unitée enrubanneuses
Unidades de precinto

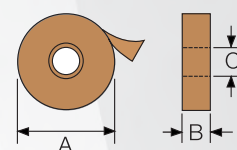

> **Box dimensions**
Dimensioni delle scatole
Kartonabmessungen
Dimensions des boîtes
Dimensiones de cajas

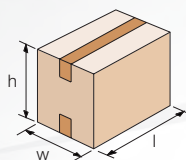

> **XL35**

	K11 / K12	
	Min.	Max
l	150	∞
w	130 / 140	500
h	100	500

> **XL35/4**

	K11	
	Min.	Max
l	150	∞
w	105	500
h	100	500

	K11 / K12	
	mm	
A	410 Max	
B	50 / 75	
C	76	

> **Production capacity**
Capacità di produzione
Produktionskapazität
Capacité de production
Capacidad de producción

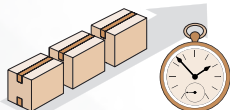

> XL35 - XL35/4	Bph
Max pcs.*	1200

* Depending on operator dexterity

> **Standard voltage**
Voltaggio standard
Standardspannung
Tension standard
Voltaje estándar

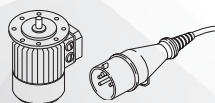

> **XL35 - XL35/4**

380/415V - 50Hz	
<i>Other voltages available on demand</i>	
Amps	1,08
Power kW	0,26
Phase	3Ph + PE

> **Optionals**
Accessori
Zubehör
Accessories
Accesorios

> **AS80**
Higher legs
Set gambe più alte
Höhere Stützen
Pieds plus hauts
Patas más altas



> **AS77**
Casters
Set ruote
Rädchen
Roulettes
Ruedas

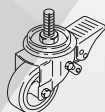

> **RG**
Roller conveyor
Piani a rulli
Rollenbahnen
Plans à rouleaux
Rodillos libres



> **GTL - GTR**
Extendable conveyor
Rulliera estensibile
Ausziehbare rollenbahnen
Convoyeur extensible
Rodillos extensibles

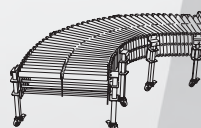

> **K-125 / K-250**
Inkjet printer
Stampante ad inchiostro
Tintenstrahldrucker
Marqueur à jet d'encre
Impresora de inyección de tinta

