

Carton Sealing Machines

XL46/XL461

SM48/SM481

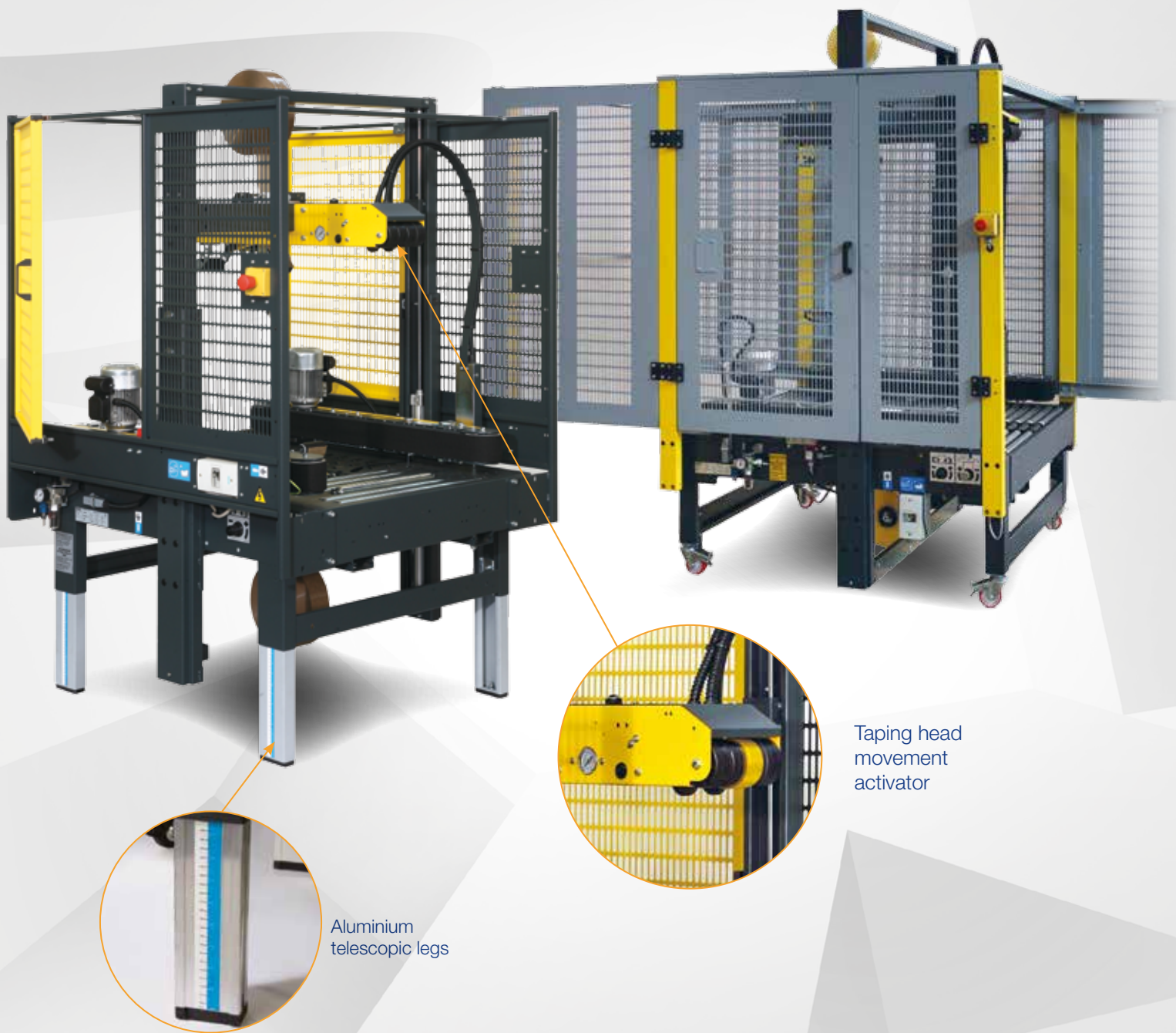

Taping head movement activator

Aluminium telescopic legs



XL46/XL461

XL46 and XL461 are semi-automatic sealing machines with random adjustment.

It means that these machines are able to adjust themselves on the different box dimensions.

The machines are designed to apply automatically a "C" strip of adhesive tape of the top and bottom of boxes.

Machines adjustments and use are intuitive, simple and fast.

On the XL46 version the rest position of the top taping unit is DOWN: the feeding of boxes is performed manually by an operator.

On the XL461 version the rest position of the top taping unit is UP: thanks to some particular devices the feeding of boxes is performed automatically.



Key Features

- Automatic adjustment on different box sizes
- Side lower drive belts (2 x 75 mm width each)
- Drive belts speed 20 m/min.
- 2 x Motors kW 0,13 each
- 2 x K12R taping unit - 75 mm width
- Extruded aluminium telescopic legs with millimetric guide
- Locked stop emergency button
- On/Off magneto-thermic switch
- Adjustable descending height stopper of the top taping unit to increase speed rate
- Top head pneumatic pressure regulators
- Safety protections with switches to disconnect electric & pneumatic circuits if opened
- Adjustable working height 445 - 705 mm

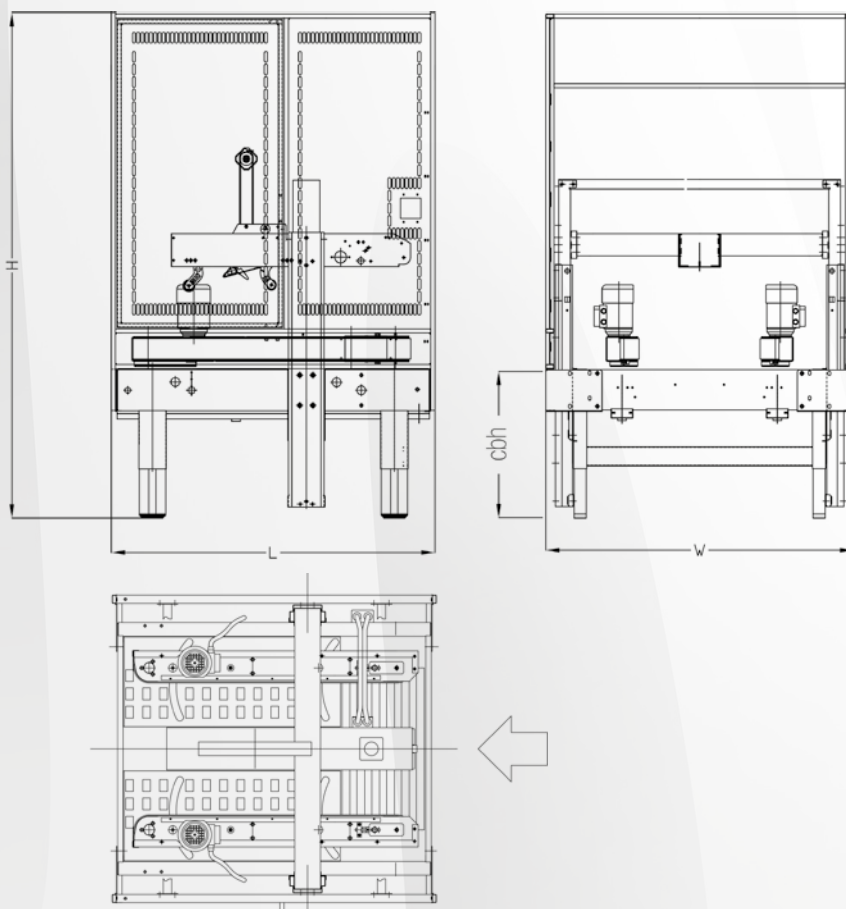

SM48/SM481

SM48 and SM481 are automatic sealing machines with random adjustment.

It means that these machines are able to adjust themselves on the different box dimensions.

Thanks to the top and bottom drive belts and the K12R taping unit, they allow the perfect sealing of the box.

Machines adjustments and use are intuitive, simple and fast.

On the SM48 version the rest position of the top taping unit is DOWN: the feeding of boxes is performed manually by an operator.

On the SM481 version the rest position of the top taping unit is UP: thanks to some particular devices the feeding of boxes is performed automatically.



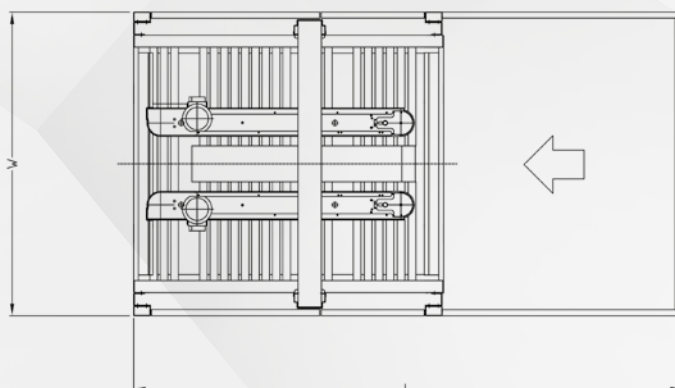
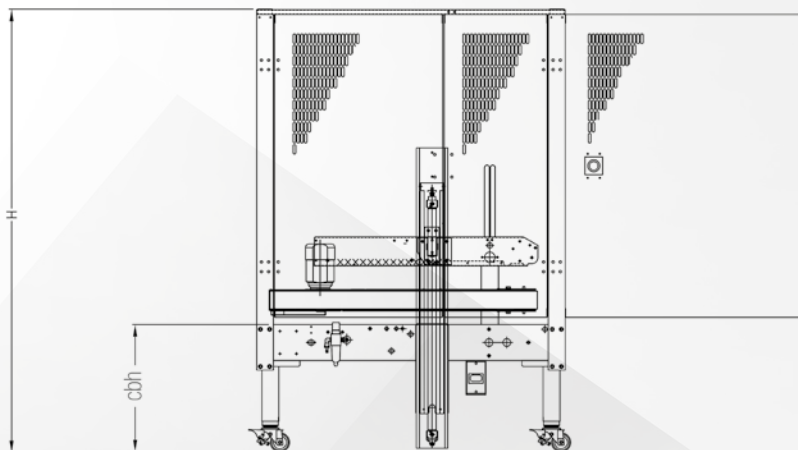

Key Features

- Automatic adjustment on different box sizes
- Side lower drive belts (2 x 75 mm width each)
- Drive belts speed 20 m/min.
- 2 x Motors kW 0,13 each
- 2 x K12R taping unit - 75 mm width
- Extruded aluminium telescopic legs with millimetric guide
- Locked stop emergency button
- On/Off magneto-thermic switch
- Adjustable descending height stopper of the top taping unit to increase speed rate
- Top head pneumatic pressure regulators
- Safety protections with switches to disconnect electric & pneumatic circuits if opened
- Adjustable working height 500 - 750 mm



> **Machine dimensions**
 Dimensioni macchina
 Machinemessungen
 Dimensions machine
 Dimensiones de máquina

Size / Weight packaging			LxWxH 
> XL46 / 461	220	295	125x125x140
> SM48 / 481	220	295	160x160x205

> **XL46 / XL 461**

	Min.	Max
L	1180	-
W	1120	-
H	1490	1750
cbh	445	705
AS 77	545	905
AS 80	645	1025

> **SM48 / SM481**

	Min.	Max
L	2280	-
W	1260	-
H	1740	1890
cbh	430	580
AS 77	530	680
AS 80	630	780

> **Box dimensions**
 Dimensioni delle scatole
 Kartonabmessungen
 Dimensions des boîtes
 Dimensiones de cajas

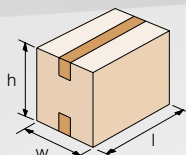

> **XL46 / XL 461**

	K12R std. / K11R on demand	
	Min.	Max
l	150	∞
w	140	650
h	100	650

> **SM48 / SM481**

	K12R	
	Min.	Max
l	200	∞
w	200	800
h	120	800

> **Taping units**
 Unità nastranti
 Verschlusseinheiten
 Unités enrubanueuses
 Unidades de precinto

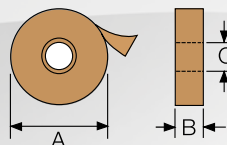

	K11R/ K12R
	mm
A	410 Max
B	50 / 75
C	76

> **Production capacity**
 Capacità di produzione
 Produktionskapazität
 Capacité de production
 Capacidad de producción

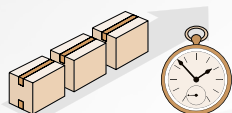

> XL46 / XL 461	Bph
Max pcs.*	600

> SM48 / SM481	Bph
Max pcs.*	600

* Always based on shorter manageable box

> **Air consumption**
 Consumo aria
 Luftverbrauch
 Consommation d'air
 Consumo de aire

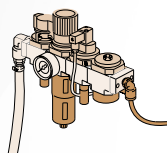

> XL46 / XL 461	NL.
Cycle	12

> SM48 / SM481	NL.
Cycle	14

from 5,5 bar to 7 bar

> **Standard voltage**
 Voltaggio standard
 Standardspannung
 Tension standard
 Voltaje estándar

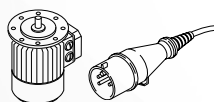

> **XL46 / XL 461**

380/400V - 50Hz - 3F	
440V - 60Hz - 3F	
Amps	1,08
Power kW	0,26
Phase	3Ph + N + PE

> **SM48 / SM481**

380/400V - 50Hz - 3F	
440V - 60Hz - 3F	
Amps	1,08
Power kW	0,26
Phase	3Ph + N + PE

> **Optionals**
 Accessori
 Zubehör
 Accessoires
 Accesorios

> **AS50**
 Higher legs
 Set gambe più alte
 Höhere Stützen
 Pieds plus hauts
 Patas más altas



> **AS77**
 Casters
 Set ruote
 Rädchen
 Roulettes
 Ruedas

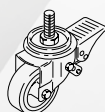

> **RG**
 Roller conveyor
 Piani a rulli
 Rollenbahnen
 Plans à rouleaux
 Rodillos libres

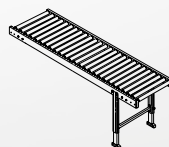

> **GTL - GTR**
 Extendable conveyor
 Rulliera estensibile
 Ausziehbare rollenbahnen
 Convoyeur extensible
 Rodillos extensibles

