

FASCIAPALLET
WRAPPING MACHINES
BANDEROLEUR
PALETTENWICKELMASCHINE
ENFARDADORA DE PALETS



PAKLET **SW2**

PAKLET

SW2

SW2L-16SM2BF



- Carrello portabobina con prestiro meccanico 30-60-90%
- Film carriage with Mechanical Pre-stretch 30-60-90%
- Chariot porte-bobine avec Prè-étirage Mécanique 30-60-90%
- Trägerrolle mit 30-60-90% angetriebener Verreckung
- Carro portabobina con Prestiro Mecanico 30-60-90%



- Pannello di controllo con N°2 programmi di fasciatura
- Control panel with N°2 wrapping programs
- Panneau commandes avec N°2 programmes de banderolage
- Schaltschrank mit nr.2 Wickelprogramme
- Panel de control con 2 programs de enfardado

- Diametro piattafarma 1650-1800 mm max. 2000 Kg
- Tuntable diameter 1650-1800 mm 2000 Kg max.
- Diamètre du plateau 1650-1800 mm max. 2000 Kg
- Drehtellerdurchmesser 1650-1800 mm 2000 Kg max.
- Diametro plataforma 1650-1800 mm max. 2000 Kg

Accessori Optional Accessoires Zubehör Accesorios

- Sistema di pesatura integrato per tutti i modelli SW2 (opzionale)
- Weighting system (only for machine version SW2)
- Groupe de pesage integre pour toutes les models SW2 (opzional)
- Integriertes Wiegunssystem für alle Modelle SW2 (opzional)
- Grupo de pesaje para todos los modelos SW2 (obcional)



SW2L-16M2
SW2L-16M2BF

SW2L-16SM4BF
SW2L-18SM4BF



- Carrello portabobina con freno meccanico
- Film carriage with mechanical brake
- Chariot porte-bobine avec frein mécanique
- Trägerrolle mit mechanischen Bremsen
- Carro portabobina con freno mecánico



- Carrello portabobina con freno elettromagnetico
- Film carriage with electromagnetic brake
- Chariot porte-bobine avec frein électromagnétique
- Trägerrolle mit elektromagnetischen Bremsen
- Carro portabobina con freno electromagnético

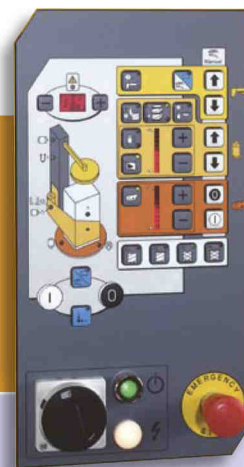

- Pannello di controllo con N°4 programmi di fasciatura
- Digital control panel with N°4 wrapping programs
- Panneau commandes avec N°4 programmes de banderolage
- Digitale Schaltschrank mit nr. 4 Wickelprogramme
- Panel de control digital con 4 programas de enfardado

- Rampa di carico
- Loading ramp
- Rampe de chargement
- Einstellbare Laderampe
- Rampa de carga

- Telaio di interrimento
- Buried Frame
- Châssis à enterrer
- Einlassrahmen
- Estructura de empotramiento

- Prolunga per pressore
- Extension for pressing unit
- Rallonge presseur
- Drukverlängerung
- Prolongación pison

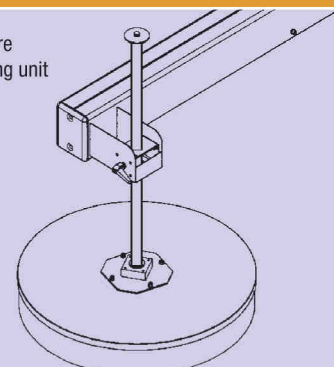
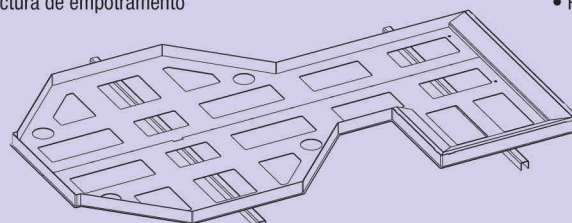

SW2L-16PW4CF SW2L-18PW4CF



- Carrello portabobina con prestiro motorizzato 125/175/250 %
- Film carriage with powered pre-stretch 125/175/250 %
- Chariot porte-bobine avec prè-étirage motorisé 125/175/250 %
- Trägerrolle mit 125/175/250 % angetriebener Verreckung
- Carro portabobina con prestiro motorizado 125/175/250 %

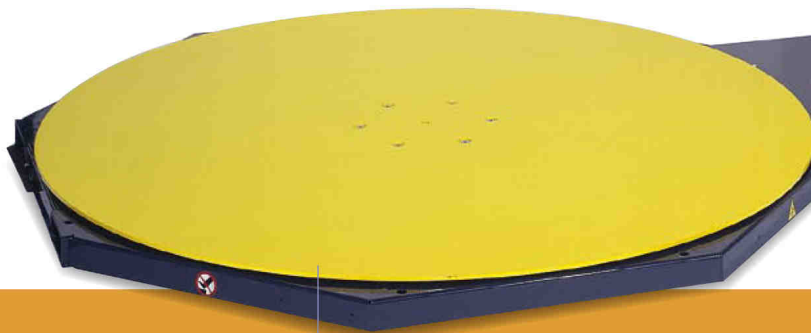

- Diametro piattaforma 1650-1800 mm max. 2000 Kg
- Tumble diameter 1650-1800 mm 2000 Kg max.
- Diamètre du plateau 1650-1800 mm max. 2000 Kg
- Drehtellerdurchmesser 1650-1800 mm 2000 Kg max.
- Diametro plataforma 1650-1800 mm max. 2000 Kg

Soluzioni per l'industria
SINTEESI

- Pressatore opzionale (disponibile per tutte le configurazioni dei modelli SW2)
- Pressing unit for unstable pallet optional (only for Version SW2)
- Presseur palet optionel (seulement pour machine model SW2)
- Anpresser opzional (verfügbar nur für SW2 Modellen)
- Pison superior (solo para maquina model SW2)

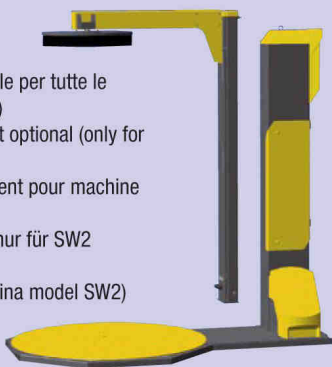

PAKLET	L	W	H	Kg max
SW2L-16M2	1200	1000	2100	2000
SW2L-16M2BF	1200	1000	2100	2000
SW2L-16SM2BF	1200	1000	2100	2000
SW2L-16FM4BF	1200	1000	2100	2000
SW2L-16PW4CF	1200	1000	2100	2000
SW2L-18FM4BF	1200	1200	2100	2000
SW2L-18PW4CF	1200	1200	2100	2000

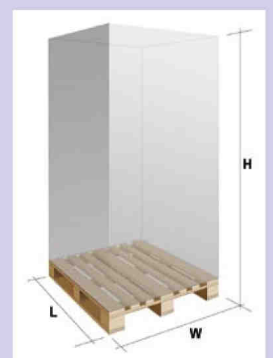



	SW2L-16M2	SW2L-16M2BF	SW2L-16SM2	SW2L-16M4BF SW2L-18M4BF	SW2L-16PW4CF SW2L-18PW4CF
Altezza Piattaforma mm.	75	75	75	75	75
Altezza bobina film mm.	500	500	500	500	500
Diametro max. bobina film mm.	300	300	300	300	300
Regolazione numero giri parte bassa/alta del pallet	■	■	■	■	■
Selettore programma Manuale/Automatoco	■	■	■	■	■
N° 4 programmi di fasciatura				■	■
Carrello con freno Meccanica	■	■			
Carrello con freno elettromagnetico				■	
Carrello non prestiro meccanico 30-60-90%			■		
Carrello con Prestiro Elettronico 125-175-250%					■
Colonna prolungata per pallet altezza 2650 mm (opzionale)	■	■	■	■	■
Colonna prolungata per pallet altezza 3000 mm (opzionale)	■	■	■	■	■
Predisposizione Pressino	■	■	■	■	■
Velocità regolabile piattaforma tramite Inverter		■	■	■	■
Fotocellula lettura altezza pallet		■	■	■	■
Velocità regolabile del carrello					■
Tensione di alimentazione 110/220 MF	■	■	■	■	■
Tensione di alimentazione 220/400 Volt 3PH	■	■	■	■	■
Potenza installa 110/220 MF	0,69 Kw	0,66 Kw	0,66 Kw	0,66 Kw	1,290 Kw
Potenza installa 220/400 Volt 3P	0,64 Kw	0,64 Kw	0,64 Kw	0,64 Kw	1,290 Kw
Dispositivo taglio film (solo sui modelli SW2L-16/18PST4CF)					■



Turntable height mm.	75	75	75	75	75
Maximum height of film mm.	500	500	500	500	500
Maximum diameter of film mm.	300	300	300	300	300
Number of wraps at the pallet base and top adjustable	■	■	■	■	■
Possibility to choose manual or automatic programs	■	■	■	■	■
N° 4 Wrapping programs				■	■
Film tension control by mechanical brake	■	■			
Film tension control by electromagnetic brake				■	
Film tension control by mecanical pre-stretch 30-60-90%			■		
Film tension control by pawered pre-stretch 125-175-250%					■
Column tu wrap pallet up to 2650 mm heigth (optional)	■	■	■	■	■
Column tu wrap pallet up to 3000 mm heigth (optional)	■	■	■	■	■
Automatic top platen unit with foam pad (optional)	■	■	■	■	■
Adjustment of turntable speed		■	■	■	■
Pallet heigth sensing photocell		■	■	■	■
Adjustment speed of film carriage					■
Power supply 110/220 MF	■	■	■	■	■
Power supply 220/400 Volt 3PH	■	■	■	■	■
Installed power 110/220 MF	0,69 Kw	0,66 Kw	0,66 Kw	0,66 Kw	1,290 Kw
Installed power 220/400 Volt 3P	0,64 Kw	0,64 Kw	0,64 Kw	0,64 Kw	1,290 Kw
Film cutting system (only for model SW2L-16/18PST4CF)					■



Hauteur du plateau mm.	75	75	75	75	75
Hauteur maximum de la bobine de film mm	500	500	500	500	500
Diamètre maximum de la bobine de film mm	300	300	300	300	300
Programmation des tours sur les partie inf./sup. de la palette	■	■	■	■	■
Possibilité de choix cycle manuel /automatique	■	■	■	■	■
N° 4 programmes de banderolage				■	■
Chariot porte-bobine avec frein mécanique	■	■			
Chariot porte-bobine avec Frein électromagnétique				■	
Chariot porte-bobine avec Pré-étirage mecanique 30-60-90%			■		
Chariot porte-bobine avec Pré-étirage motorisé 125-175-250%					■
Colonne pour banderolage pallettes H 2650 mm (optionel)	■	■	■	■	■
Colonne pour banderolage pallettes H 3000 mm (optionel)	■	■	■	■	■
Presseur automatique avec disque revêtu mousse (optionel)	■	■	■	■	■
Vitesse réglable du plateau		■	■	■	■
Cellule photo-életrique pour détection hauteur palette		■	■	■	■
Vitesse réglable du chariot					■
Alimentation eletrica 110/220 MF	■	■	■	■	■
Alimentation eletrica 220/400 Volt 3PH	■	■	■	■	■
Puissance machine 110/220 MF	0,69 Kw	0,66 Kw	0,66 Kw	0,66 Kw	1,290 Kw
Puissance machine 220/400 Volt 3P	0,64 Kw	0,64 Kw	0,64 Kw	0,64 Kw	1,290 Kw
Dispositif coupe film (soulement pour model SW2L-16/18PST4CF)					■



	SW2L-16M2	SW2L-16M2BF	SW2L-16SM2	SW2L-16M4BF SW2L-18M4BF	SW2L-16PW4CF SW2L-18PW4CF
Drehtellerhöhe mm.	75	75	75	75	75
Folienrollenhöhe mm.	500	500	500	500	500
Max. Durchmesser der Folienrolle mm.	300	300	300	300	300
Regulierung der oberen und unteren Wicklungen der Palette	■	■	■	■	■
Programmwähler manuell/automatisch	■	■	■	■	■
N° 4 Wickelprogramme				■	■
Trägerrolle mit mechanischen Bremsen	■	■			
Trägerrolle mit Elektromagnetbremsen				■	
Trägerrolle mit 30-60-90% mechanischer Verreckung			■		
Trägerrolle mit 125-175-250% elektronischer Verreckung					■
Verlängerte Säule für 2650 mm Palettenhöhe (züberhor)	■	■	■	■	■
Verlängerte Säule für 3000 mm Palettenhöhe (züberhor)	■	■	■	■	■
Vorbereitet um Anpresser anzunehmen (züberhor)	■	■	■	■	■
Drehtellergeschwindigkeit mittels Inverter einstellbar		■	■	■	■
Photozelle zum Lesen der Palettenhöhe		■	■	■	■
Verstellbare Geschwindigkeit vom Trägerrolle					■
Spannung 110/220 Einphasig	■	■	■	■	■
Spannung 220/400 Volt 3PH	■	■	■	■	■
Installierte Spannung 110/220 MF	0,69 Kw	0,66 Kw	0,66 Kw	0,66 Kw	1,290 Kw
Installierte Spannung 220/400 Volt 3P	0,64 Kw	0,64 Kw	0,64 Kw	0,64 Kw	1,290 Kw
Folienabschneidvorrichtung (nur auf Mod. SW2L-16/18PST4CF)					■



	75	75	75	75	75
Altura plataforma mm.	75	75	75	75	75
Altura máxima bobina film mm.	500	500	500	500	500
Diametro max. bobina film mm.	300	300	300	300	300
Programación vueltas en la base del palet y en la parte superior	■	■	■	■	■
Posibilidad de trabajo en ciclo manual o automático	■	■	■	■	■
4 Programas de enfardado				■	■
Carro con freno mecanico	■	■			
Carro con freno electromagnético				■	
Carro con prestiro mecanico 30-60-90%			■		
Carro con prestiro motorizado 125-175-250%					■
Mastil para palet H= 2650 mm (opcional)	■	■	■	■	■
Mastil para palet H= 3000 mm (opcional)	■	■	■	■	■
Pison automático con recubrimiento de goma (opcional)	■	■	■	■	■
Velocidad regulable de la plataforma		■	■	■	■
Fotocelula para la lectura automática de la altura del palet		■	■	■	■
Velocidad regulable del carro portabobina					■
Alimentación eléctrica 110/220 MF	■	■	■	■	■
Alimentación eléctrica 220/400 Volt 3PH	■	■	■	■	■
Potencia eléctrica instalada 110/220 MF	0,69 Kw	0,66 Kw	0,66 Kw	0,66 Kw	1,290 Kw
Potencia eléctrica instalada 220/400 Volt 3P	0,64 Kw	0,64 Kw	0,64 Kw	0,64 Kw	1,290 Kw
Unidad de corte film (solo para modelo SW2L-16/18PST4CF)					■

SW2L-16M2BF

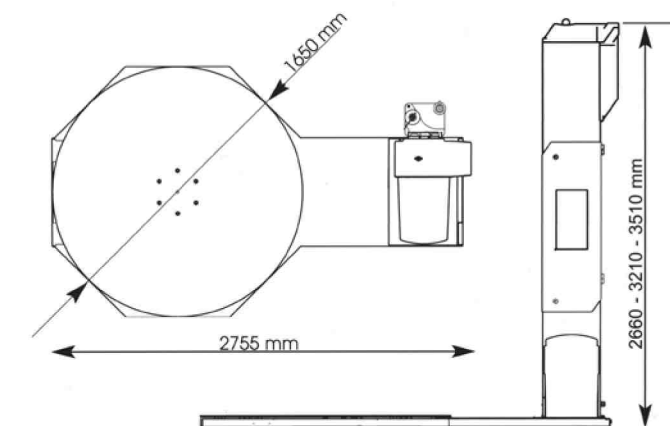

SW2L-18M2BF

